



**DIPLOMATIC**  
HYDRAULICS

89 110/104 ED



# EPC

## ELECTRONIC CONTROL UNIT FOR OPEN LOOP SINGLE SOLENOID PROPORTIONAL VALVE SERIES 11

**PLUG VERSION**

### FUNCTIONAL BLOCK DIAGRAM

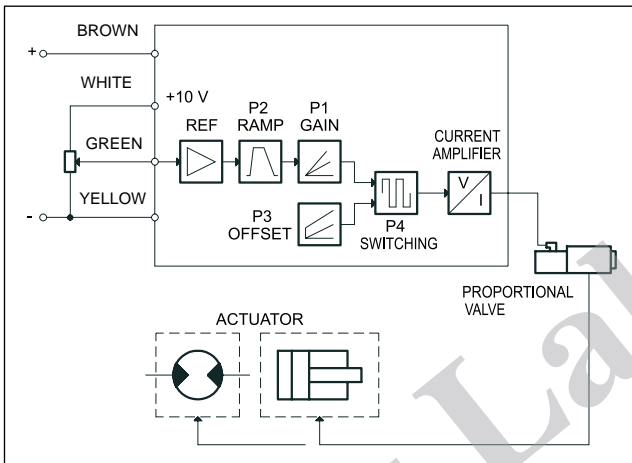

### SPECIFICATIONS

Power supply	VCC	10 ÷ 30 Ripple included
Required power	W	see par. 2.1
Output current	A	see par. 1 and 5
Reference signal	standard optional	V 0 ÷ +10 0 ÷ +5
Input reference signal impedance	kΩ	100
Electrical connection	DIN 43650	
Electromagnetic compatibility (EMC)	in compliance with 89/336 EEC	
	- EMISSIONS	EN 50081-1
	- IMMUNITY	EN 50082-2
	(see par. 4 - note 1)	
Protection to atmospheric agents (according to IEC 144 standard)	IP 67	
Operating temperature range	°C	-20 ÷ +70
Mass	kg	0,20

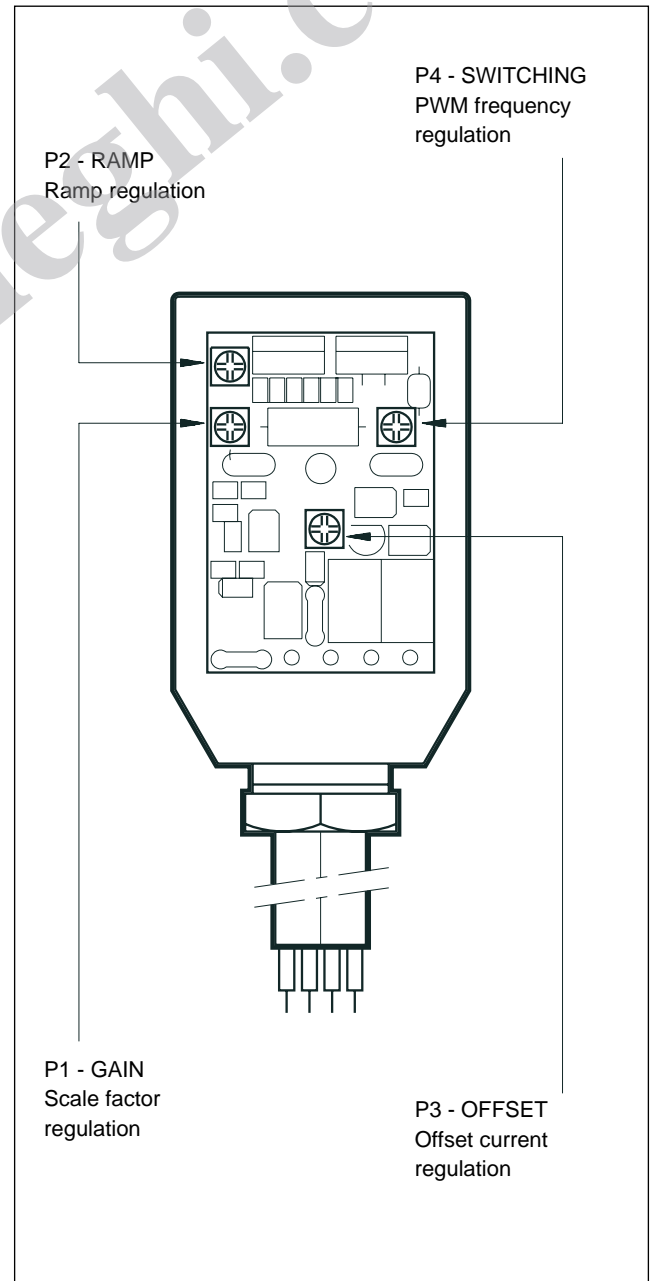



### 1 - IDENTIFICATION CODE

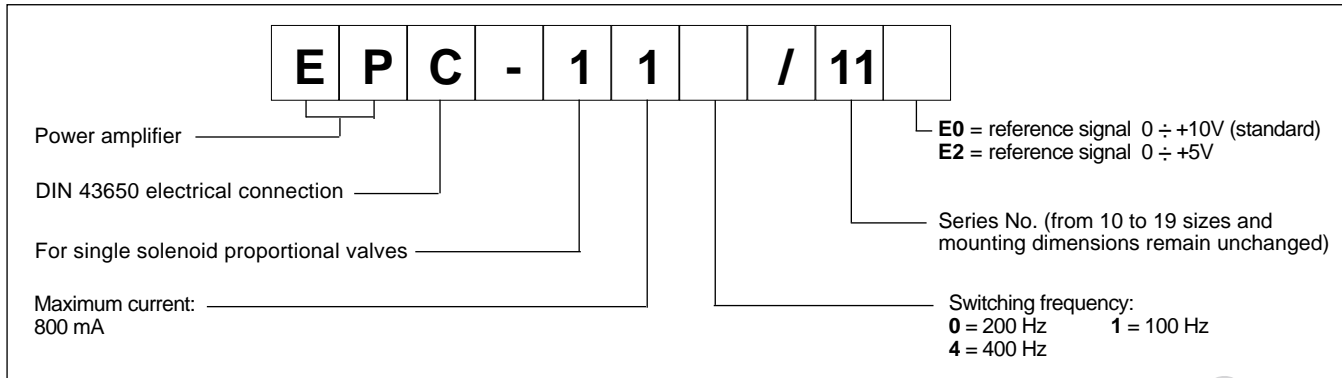

The EPC unit is a miniaturised electronic control unit for open loop proportional valves, designed in plug version in compliance with DIN 43650, for direct mounting on the valve solenoid.

The unit supplies a variable current in proportion to the input reference signal and independently of temperature variations or load impedance.

The PWM stage on the solenoid power supply makes it possible to reduce valve hysteresis thus optimising control precision. Potentiometers are also fitted for optimal calibration, and can be accessed by slackening the relative screw and opening the cover of the connector.

### 2 - FUNCTIONAL SPECIFICATIONS

#### 2.1 - Electric power supply

The card requires a power supply of between 10 and 30 VDC (ripple included).

**NOTE: The value of the power supply voltage on the card must not be lower than the rated working voltage of the solenoid to be controlled.**

The power supply voltage must be rectified and filtered, with maximum admissible ripple within the above voltage range. The power required by the card depends on the power supply voltage. In general a conservative value of the required power can be considered as the product of  $V \times I$ .

Example: a card with a maximum current = 800 mA and a power supply voltage of 24 Vcc requires a power of about 20W.

**NB. Observe wire polarity and protect the power supply circuit from overvoltages.**

#### 2.2 - Reference signal

The card accepts voltage reference signals of 0 ÷ +10V.

**N.B: If the signal is transmitted by potentiometer, please verify that this has a load of at least 5 K $\Omega$  (recommended 10 K $\Omega$ ).**

See par. 7 for electrical connections.

### 3 - ADJUSTMENT

#### 3.1 - P1 - GAIN (Scale factor regulation)

Potentiometer "P1" enables regulation of the relation between the set reference value and the current supplied to the solenoid, and therefore regulation of the hydraulic parameter controlled by the valve.

Adjustment range = 0 ÷ 100 % of maximum current

Single turn potentiometer - Rotate clockwise to increase current.

#### P1 ADJUSTMENT RANGE

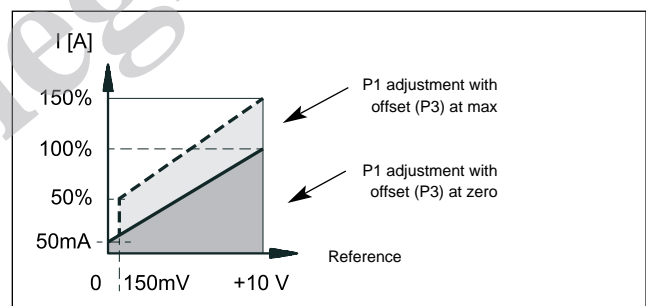

#### 3.2 - P2 - RAMP (Ramp regulation)

Potentiometer "P2" within a range from 0,03 to 1,5 sec. regulates the time required to reach the current according to a step change of the reference signal up or down.

This makes it possible to control valve response and adapt it to the requirements of the hydraulic system and the machine cycles.

Single turn potentiometer - Rotate clockwise to increase ramp time.



### 3.3 - P3 - OFFSET (Offset current regulation)

Potentiometer "P3" enables regulation of the offset current of the valve.

This is used to eliminate the valve insensitivity zone (dead zone).

The offset current is activated when the reference signal exceeds the threshold of + 150 mV.

The offset is not active and only the polarization current equal to 25 mA is present beneath this threshold.

**NOTE:** The variation of the set value of the offset current causes a corresponding variation of the scale factor value setted on P1 potentiometer.

Adjustment range = 0 ÷ 50 % of maximum current

Single turn potentiometer - Rotate clockwise to increase current.

### 3.4 - P4 - SWITCHING (PWM frequency regulation)

It is possible to change the switching frequency (PWM) by acting on the trimmer P4.

The setting range is from 140 to 400 Hz.

An appropriate switching frequency adjustment allows reduction of the valve hysteresis value.

Single turn potentiometer - Clockwise rotation to increase the frequency.

**NOTE: The potentiometer setting is sealed with a red coating and it must never be adjusted by the user.**

## 4 - INSTALLATION

The connector type electronic unit is suitable for direct assembly on the solenoid of the relative proportional valve.

The 4-core connection cable (0,5 mm<sup>2</sup> individual wire section) is supplied pre-wired and in a standard length of 2,5 m (DIN 47100 standard).

### NOTE 1

To observe EMC requirements it is important that the control unit electrical connection is in compliance with the wiring diagram of par. 7. As a general rule, the valve and the electronic unit connection wires must be kept as far as possible from interference sources (e.g. power wires, electrical motors, inverters and electrical switches).

In environments that are critical from the electromagnetic interference point of view, a complete protection of the connection wires can be requested.

## 5 - DEFAULT CONDITIONS

The electronic control unit is supplied factory-set.

Standard settings are:

Identification code	ADJUSTMENTS			
	P1 GAIN [mA]	P2 RAMP [mA]	P3 OFFSET [mA]	P4 SWITCHING [mA]
EPC - 110	800	regulation at minimum	regulation at minimum	200
EPC - 111	800			100
EPC - 114	800			400

## 6 - START UP AND CONTROL SETTINGS

If required, settings can be modified as follows:

### a) OFFSET CURRENT REGULATION

- Set potentiometer "P1" to minimum.
- Enter the maximum reference signal value (+10V).
- Set potentiometer "P3" so that the valve is positioned at the start of the work zone.

### b) SCALE FACTOR REGULATION

- Enter the maximum reference signal value (+10V).
- Set potentiometer "P1" so that the controlled hydraulic parameter reaches the maximum required value.

**NOTE: The maximum current value must be compatible with the maximum current prescribed by the technical table of the connected proportional valve.**

### c) RAMP REGULATION

- Set potentiometer "P2" to smooth valve response according to reference signal variations.



7 - CARD CIRCUIT AND WIRING DIAGRAM

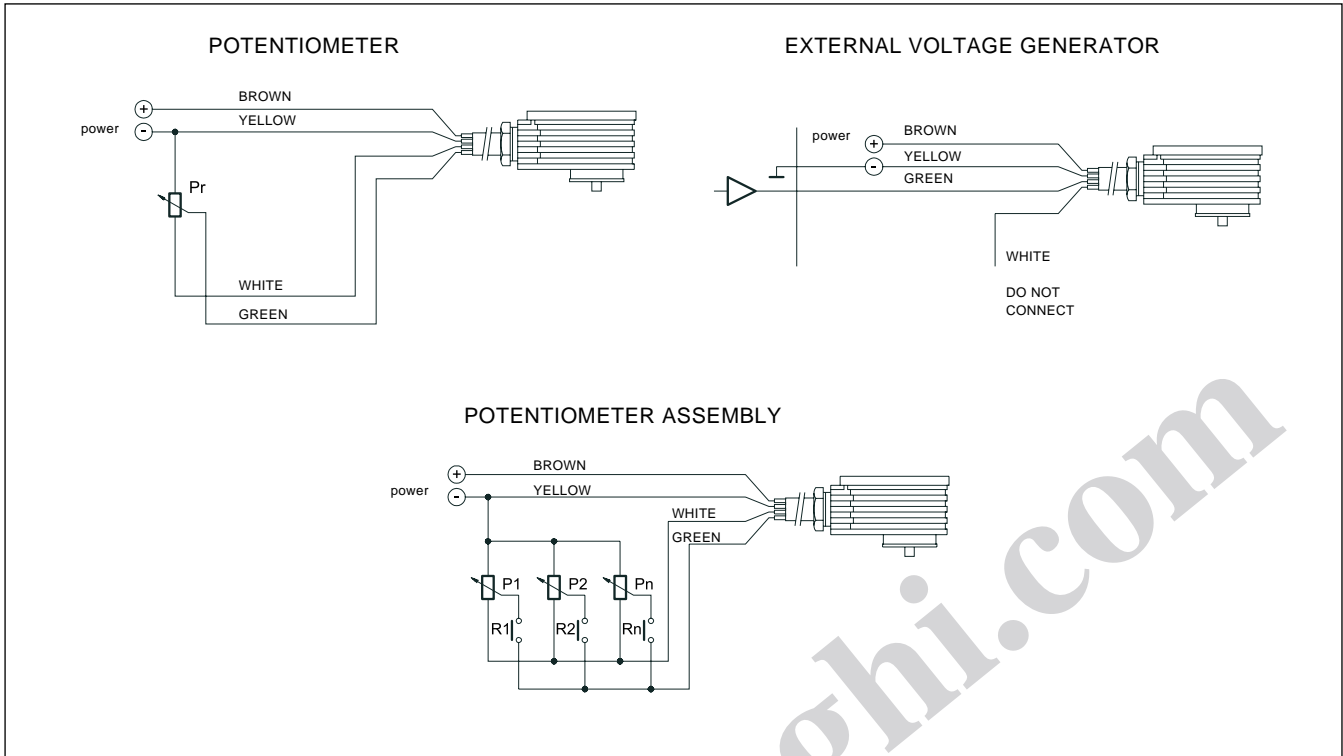

8 - OVERALL AND MOUNTING DIMENSIONS

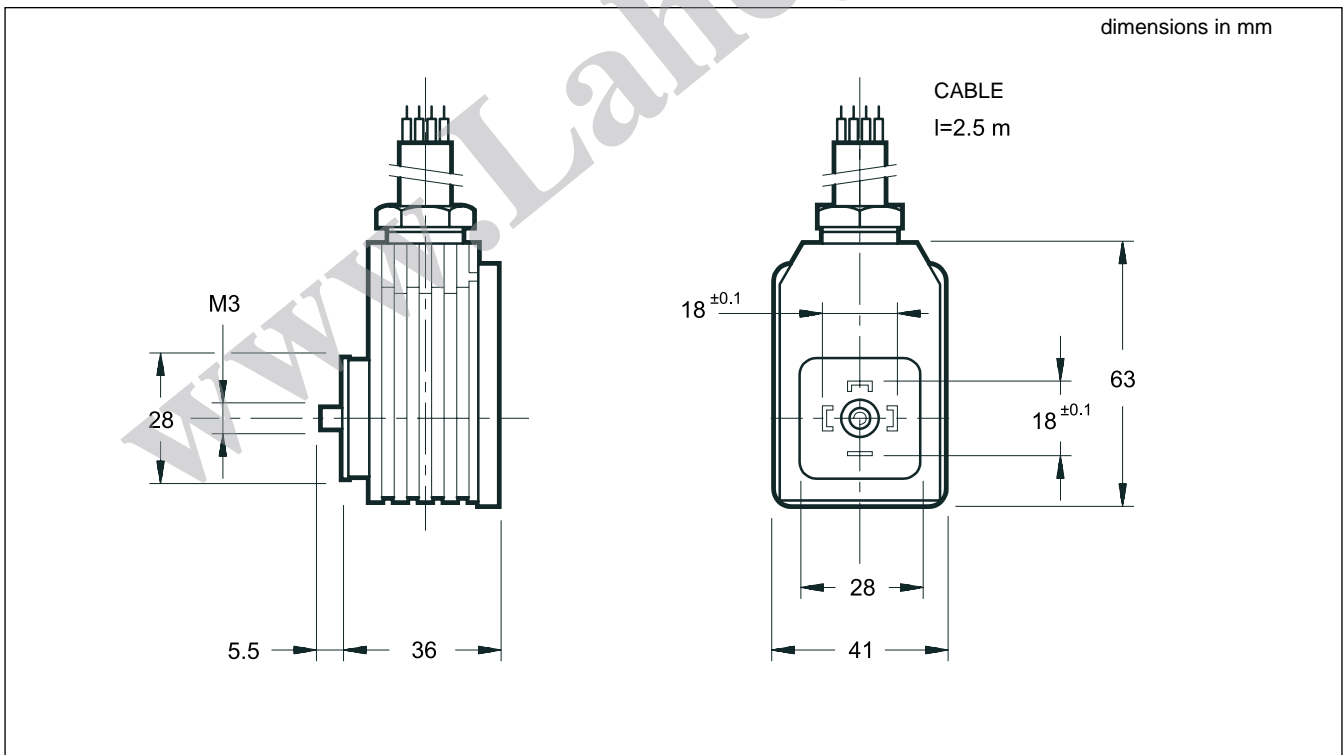

DIPLOMATIC  
HYDRAULICS

DIPLOMATIC OLEODINAMICA SpA  
20025 LEGNANO (MI) - P.le Bozzi, 1 / Via Edison  
Tel. 0331/472111 - Fax 0331/548328